

fittings with tyton joint
formstücke mit tyton-verbinding
fazonski komadi sa tyton-spojem

фазонски делови со tyton-спој



Фазонските делови од овој тип се наменети за вградување во водоводни гасни и други видови инсталации како споеви со вметнување. Деловите ги изработуваме од нодуларен и од сив лив за работен притисок од 10 и 16 бари. Заштитата на деловите ја вршиме со материјал кој не го загрозува здравјето на луѓето. Испитувањето на деловите се врши под притисок од 25 бари.

Fittings from this type are intended for embedment in water conduit, gas and other kinds of installations as junctions with insertion. Parts are made from ductile and gray iron with working pressure as 10 and 16 bar. Protection of products is performed with material which is safe for human health. Testing of products is made under pressure as 25 bars.

Die Formstücke dieser Art sind zum Einbauen in Wasserleitungen und andere Instalationen als Verbindungsstücke/Kupplungen mit Einsetzen bestimmt. Die Teile werden aus Duktilen- und Grau-gusseisen gefertigt und sind für einen Arbeitsdruck von 10 und 16 Bar geeignet. Der Schutz der Teile wird mit einem Material, welcher die Gesundheit der Menschen nicht gefährdet, ausgeführt. Die Erprobung der Teile wird unter einem Druck von 25 Bar geprüft.

www.learnica.com.mk

ul. Pero Nakov bb 1000 Skopje, Makedonija
tel. +(389 02) 2549-813, 2549-776, 2549-775
fax: +(389 02) 2549-771
e-mail: learnica@mt.net.mk



фазонски делови со tyton-спој

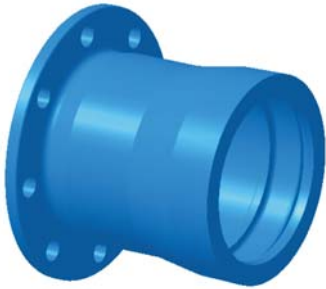

- EU парче со прирабница и tyton-спој
- EU flanged and tyton socket pieces
- EU stücke flansch muffenstücke tyton-muffen
- EU komad sa prirubnicom i tyton-spoj

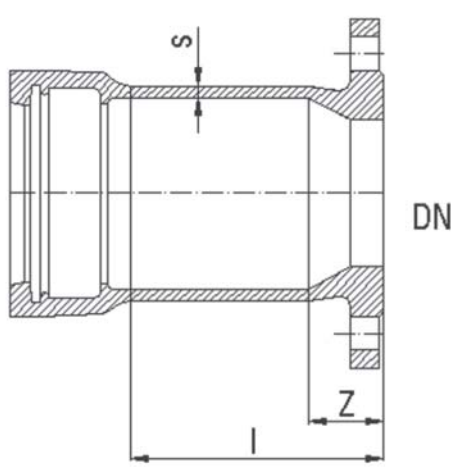

EU EN 545 DIN 28622 GJS

DN	L	Z	S	masa weight gewicht masa (kg)	
				PN10	PN16
80	130	86	7	7.6	7.6
100		87	7.2	9.1	9.1
125	135	91	7.5	12.5	12.5
150		92	7.8	15.3	15.3
200	140	97	8.4	20	19.8
250	145	102	9	29	28.5
300	150	107	9.6	36.5	35.5
350	155	112	10.2	43	46
400	160	117	10.8	52	57
500	170	127	12	75	90.2
600	180	137	13.2	104	128



- U спојно парче со tyton-спој
- U duple-tyton socket collars
- U stücke mit tyton-muffen (Ü-stücke)
- U spojni komad sa tyton-spojem

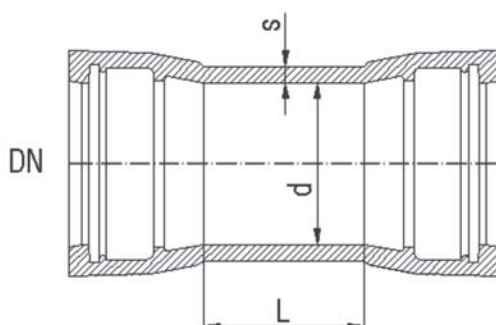

U EN 545 DIN 28624 GJS

DN	L	d	S	masa weight gewicht masa (kg)	
80	160	109	7	7.7	
100		130	7.2	10.1	
150	165	183	7.8	15.8	
200	170	235	8.4	22	



MMB **огранок со tyton-споеви**

MMB tyton tees

MMB doppelmuffe mit tyton muffenstutzen

MMB ogranak sa tyton-spojevima

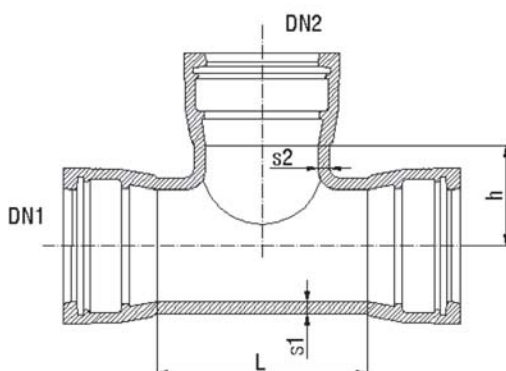

MMB EN 545 DIN 28632

GJS

DN1	DN2	L	h	S1	S2	masa weight gewicht masa	(kg)
100	100	190	95	7.2	7.2	14.2	
150	100	195	120	7.8		21	
150	150	255	125		7.8	25.5	



MMR **редуцир со tyton-споеви**

MMR tyton concentric tapers

MMR doppelmuffen Übergangestücke

MMR reducir sa tyton-spojevima

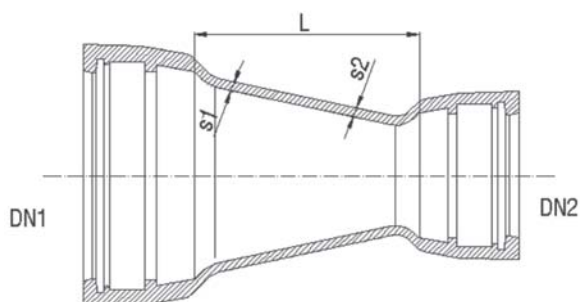

MMR EN 545 DIN 28634

GJS

DN1	DN2	L	S1	S2	masa weight gewicht masa	(kg)
100	80	90	7.2	7.0	7.5	
150	100	150	7.8	7.2	12.8	

фазонски делови со tyton-спој

- MMK 11° лак со tyton-споеви 11 1/4°**
 MMK 11° tyton 11 1/4 bends°
 MMK 11° stücke mit tyton-muffen 11 1/4°
 MMK 11° luk sa tyton-spojevima 11 1/4°

MMK 11° EN 545 DIN 28629 GJS

DN	<i>b</i>	<i>s</i>	маса weight gewicht masa	(kg)
80	30	7	6.5	
100		7.2	7.8	
125	35	7.5	13	
150		7.8	13.4	
200	40	8.4	19.6	

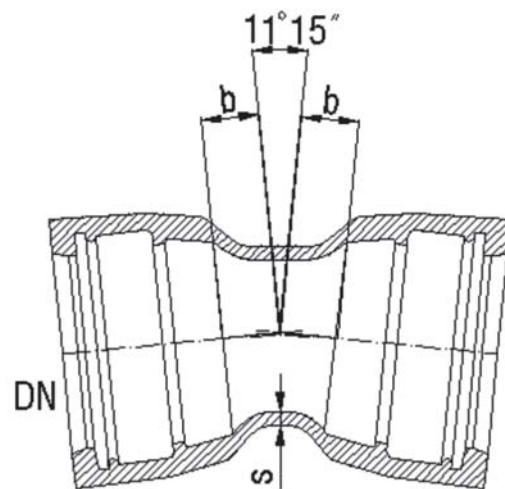

- MMK 22° лак со tyton-споеви 22 1/2°**
 MMK 22° tyton 22 1/2° bends
 MMK 22° stücke mit tyton - muffen 22 1/2°
 MMK 22° luk sa tyton spojevima 22 1/2°

MMK 22° EN 545 DIN 28628 GJS

DN	<i>b</i>	<i>s</i>	маса weight gewicht masa	(kg)
80	40	7	6.7	
100		7.2	8.1	
125	50	7.5	14.3	
150	55	7.8	14.2	
200	65	8.4	21	

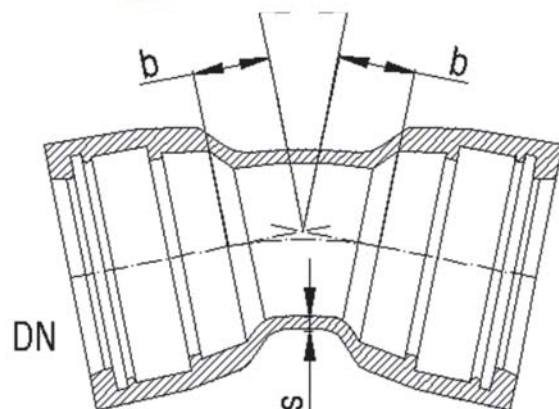

MMK 45° лак со tyton-споеви 45°
 MMK 45° tyton 45° bends
 MMK 45° stücke mit tyton-muffen 45°
 MMK 45° luk sa tyton-spojevima 45°



MMK 45° EN 545 DIN 28626 GJS

DN	<i>b</i>	<i>s</i>	маса weight gewicht masa	(kg)
80	55	7	7.1	
100	65	7.2	8.8	
125	75	7.5	14.5	
150	85	7.8	15.9	
200	110	8.4	24.5	

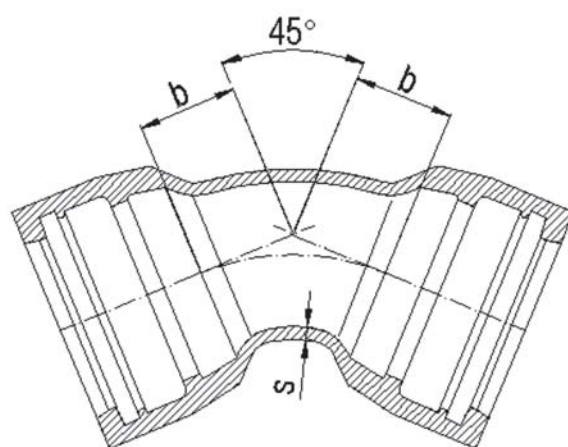

MMK 30° лак со tyton-споеви 30°
 MMK 30° tyton 30° bends
 MMK 30° stücke mit tyton-muffen 30°
 MMK 30° luk sa tyton-spojevima 30°



MMK 30° EN 545 DIN 28627 GJS

DN	<i>b</i>	<i>s</i>	маса weight gewicht masa	(kg)
80	45	7	6.8	
100	50	7.2	8.3	
125	55	7.5	13.4	
150	65	7.8	14.8	
200	80	8.4	22	

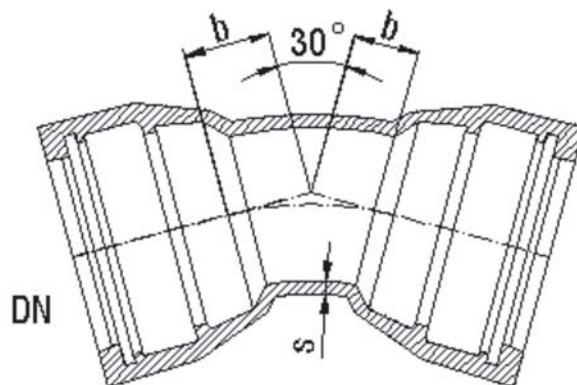

фазонски делови со tyton-спој



MMQ 90° лак со tyton-споеви 90°
MMQ 90° tyton 90° bends
MMQ 90° stücke mit tyton-muffen 90°
MMQ 90° luk sa tyton-spojevima 90°

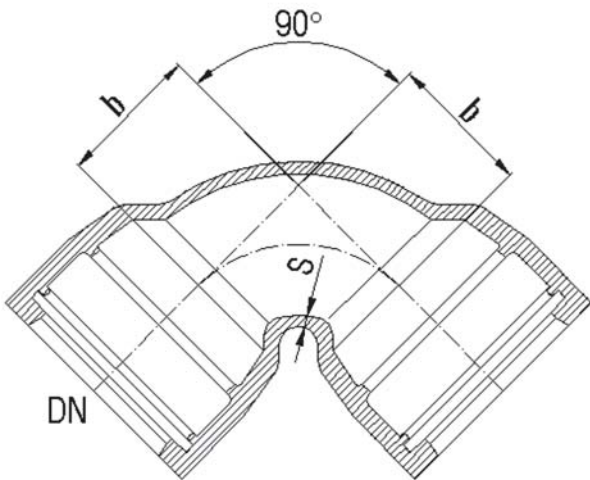

MMQ EN 545 DIN 28625 GJS

DN	b	s	masa weight gewicht masa	(kg)
80	100	7	9	
100	120	7.2	13	
125	145	7.5	17.2	
150	175	7.8	23.9	
200	225	8.4	***нема модел no model	



MMA парче со tyton-споеви и прирабница
MMA flange on tyton tee
MMA stücke mit tyton-muffen
MMA komad sa tyton-spojevima i prirubicom

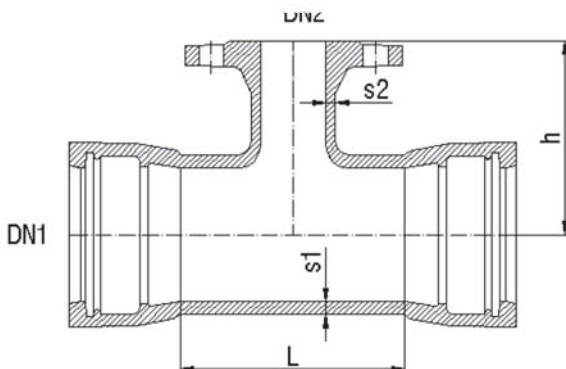

MMA EN 545 DIN 28630 GJS

DN1	DN2	L	h	s1	s2	masa weight gewicht masa	(kg)
80	80	170	165	7	7	13.6	
	80		175			14.7	
100	80	190	180	7.2	7.2	15.9	
	100		190			19.5	
125	80	170	190	7.5	7	19.5	
	80		205			21.8	
	100		210			23	
150	100	195	210	7.8	7.2	23	
	150		220			28	
	150		220			28	
200	80	175	235	8.4	7	28.5	
	200		260			43	
	200		260			43	